

TRAV'LER by ELIXIR

**ABSORPTION
REFRIGERATOR**

OWNER'S MANUAL

INSTALLATION

OPERATION

ELIXIR INDUSTRIES
GARDENA, CALIFORNIA

Trav'ler by ELIXER

INTRODUCTION

We at **TRAV'LER** are pleased to add you to the growing number of satisfied users of **TRAV'LER** Gas/Electric Refrigerators.

We sincerely believe that you will receive years of dependable service from your investment.

We suggest that you get to know something about your new Gas/Electric Refrigerator. You can do this by reading through this manual before you start to use it.

This manual is prepared to help you operate and maintain your refrigerator more efficiently. Keep it in a safe convenient place.

Should you have further questions pertaining to your new TRAV'LER refrigerator, please feel free to contact us by mail or in person.

ELIXIR INDUSTRIES

17809 South Broadway	2040 Industrial Parkway
Gardena, California 90248	Elkhart, Indiana 46514
(213) 321-1191	(219) 294-1651

INDEX

PAGE

1 - 3	Parts
4 - 6	Operation
7 - 8	Maintenance/ Trouble Shooting
9 - 15	Installation Instructions

MAJOR PARTS DESCRIPTIONS Model 202-90

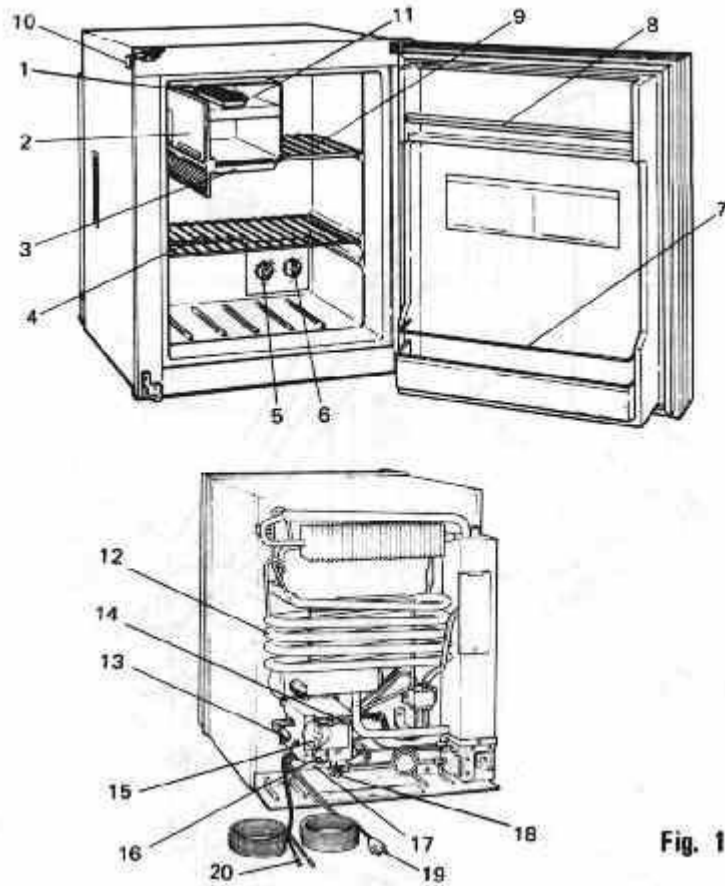

Fig. 1

<u>ITEM</u>	<u>PART</u>	<u>PART NO.</u>	<u>ITEM</u>	<u>PART</u>	<u>PART NO</u>
1.	Ice Tray	2112-168-131-10	11.	Ice Making Compartment	
2.	Ice Maker Door	2102-146-131-10	12.	Cooling Unit	
3.	Defrost (Drip) Tray.	2112-156-111-10	13.	Gas Connector	2112-181-151-10
4.	Storage Shelf	2112-168-112-05	14.	Slide Switch	2112-184-141-05 / 2112-184-142-05
5.	Gas Temperature.. Control Knob	2112-182-162-10	15.	Gas ON/OFF Knob	2112-182-161-10
6.	Electric Temperature. Control Knob	2112.182-162-10	16.	Ignition Lever	
7.	Bottle Rack	2112-152-141-10	17.	Ignition Button	
8.	Dairy Support Bar	2112-152-145-10	18.	Pressure Testing Outlet	2116-180-181-12
9.	Flip-up Storage Shelf.	2112-168-111-05	19.	AC. Supply Cord	2112-184-161-10
10.	Travel Latch		20.	D.C. Supply Cord	2112-184-163-10

CONTROL SYSTEM DIAGRAM

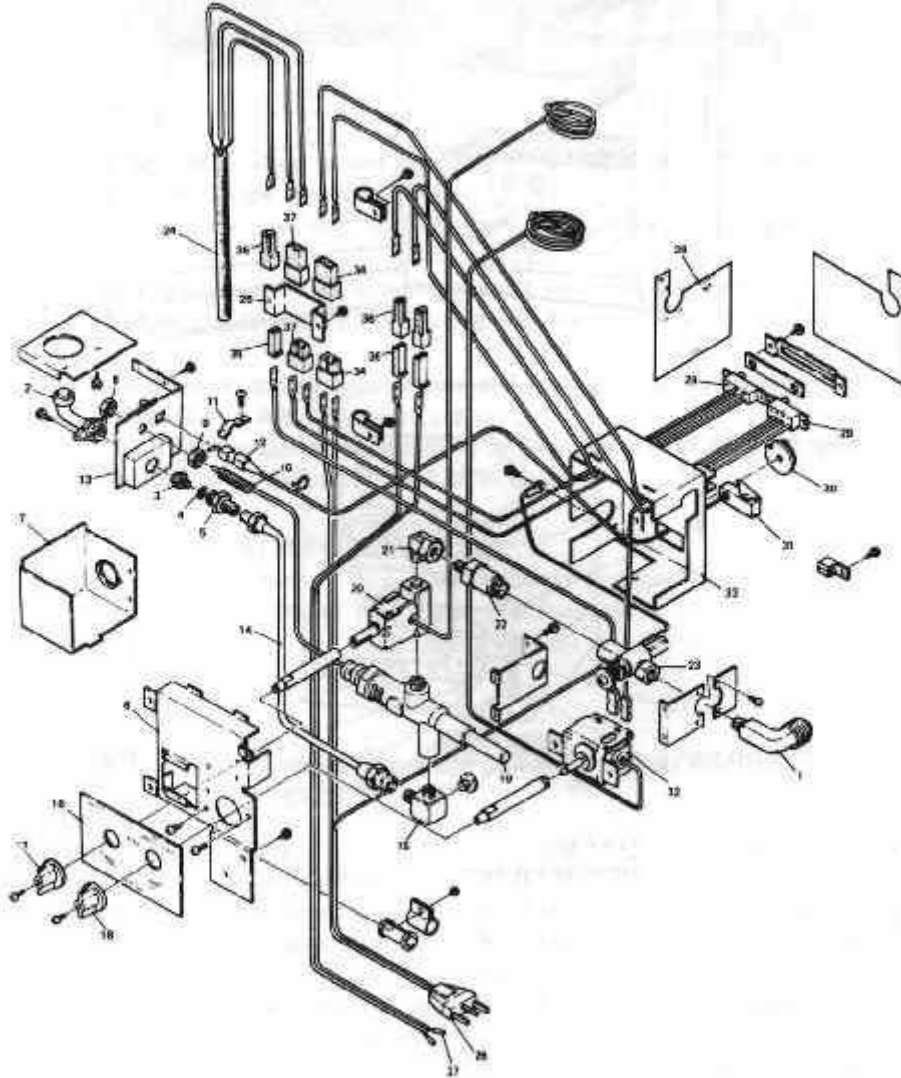

Fig. 2

ITEM	PART	PART NO
1).	Gas Connector.	2112-181-151-10
2).	Burner	2112-181-111-05
3).	Burner Orifice	2112-181-113-10
4).	Burner Filter	2116-181-115-10
5).	Borne, Joint	2112-181-132-10
6).	Control Bracket	2112-180-151-11
7).	Flame Blow-out Guard	2112-122-121-05
8).	Position Nut	2112-181-126-11
9).	Lock Nut	2112-181-126-12
10).	Thermocouple	2112-181-124-10
11).	Ignition Plug Bracket	2116-181-131-14
12).	Ignition Plug	2116-181-262-05
13).	Burner Bracket	2112-181-131-05
14).	Gas Pipe	2112-182-131-10
15).	Pressure Testing Outlet	2112-180-181-11
16).	Thermostat Dial Plate	2112-194-131-10
17).	Gas Temperature Control Knob	2112-182-162-10
18).	Electric Temperature Control Knob	2112-182-162-10
19).	Flame Failure Device (Ignition Button)	2112-181-121-10
20).	Gas Thermostat	2116-180-191-10
21).	Elbow	2112-180-161-10
22).	Gas Filter	2116-182-141-05
23).	Gas Cock	2112-181-141-05
24).	Heater	2112-184-112-05
25).	Bracket	2112-185-118-10
26).	AC. Supply Cord	2112-184-161-10
27).	D.C. Supply Cord	2112-184-163-10
28).	ON/OFF Plate	2112-194-121-10
29).	Slide Switch	2112-184-141-05 / 2112-184-142-05
30).	Gas ON/OFF Knob	2112-182-161-10
31).	Ignition Device	2112-181-161-10
32).	Electric Thermostat	2112-184-134-05
33).	Control Cover	2112-180-152.10
34).	Connector Housing	2112-185-112-12
35).	Connector Housing	2116-185-112-13
36).	Connector Housing	2112-185-112-14
37).	Connector Housing	2116-185-111-05

1. PRELIMINARY INSTRUCTIONS (Setting Up of Accessories)

Turn to the pictorial diagram in Fig. 1 on Page 1.

Place the following accessories incorrect positions respectively.

- (a) Ice Tray with divisions (item 1) in the Ice Making Compartment
- (b) Defrost (Drip) Tray (item 3) under the Evaporator.
- (c) Storage Shelves (item 4,9)

2. CONTROLS

The cold controls for gas and electric operation are inside the food storage compartment on the right side in the rear. The “on-off” switches, gas on-off, igniter, and the safety valve is located on the back of the unit outside toward the base.

3. STARTING-Up

3-1 Gas Operation

To start up the refrigeration using L.P. Gas (Bottled Gas):

- 1) Be sure the refrigerator is level. A spirit level is supplied with the refrigerator. Place this level in the ice making compartment to check the level of the refrigerator front to back and side to side.
- 2) Turn on the LP. Gas supply of the bottle.
- 3) Open the service access door.
- 4) Set the Elec. DC-AC-OFF Slide Switch (14) to “ELEC OFF” position.
- 5) Set the Gas ON/OFF Knob (15) to “GAS ON” position.
- 6) Push the Ignition Button (17) of the flame failure device and press the Ignition Lever (16) of the piezo lighter. The pressing of the Ignition Lever has to be repeated until the gas is lit at the burner.
- 7) Release the Ignition Button about 20 seconds after the burner flame has been on.

IMPORTANT

As air may be present in the gas lines at the first ignition, it may be necessary to repeat the starting-up ignition procedure.

- 8) Turn the Gas Temperature Control Knob (5) to “COLDEST” setting.
- 9) If the cabinet is found too cold, turn the Gas Temperature Control Knob to a warmer setting.

3-2 Electric Operation (A.C.: 117V, D.C.: 12V)

To startup the refrigerating operation using electricity:

- 1) Be sure the refrigerator is level. A spirit level is supplied with the refrigerator. Place this level in the ice making compartment to check the level of the refrigerator front to back and side to side.
- 2) Open the service access door.
- 3) Plug in the power cord to the 117V supply receptacle.
- 4) Turn the Gas ON/OFF Knob (15) to “GAS OFF” position, and slide the Electric DC-AC-OFF Slide Switch (14) to left: “AC or DC”. Be sure to locate the slide head just below the AC or DC marking, respectively, according to the electric current selected.
- 5) Turn the Electric Temperature Control Knob (6) to “COLDEST” setting.
- 6) In case the cabinet is found too cold, turn the Electric Temperature Control Knob (6) to a warmer setting.

4. OPERATION CHANGE

4-1 From Electricity to Gas

- 1). Follow the starting up instructions of “Gas Operation” Para. 3-1. Be sure to set the Electric DC-AC-OFF Slide Switch (14) to “ELEC OFF” position.
- 2). When the burner is lit, turn the Gas Temperature Control Knob (5) to a desired setting position.

4-2 From Gas to Electricity

- 1). Follow the starting up instructions of “Electric Operation” Para. 3-2.
- 2). Turn the Electric Temperature Control Knob (6) to a desired setting position.

5. ICE MAKING

Ice cubes take some time to form and it is advisable to keep the ice tray full and ready for immediate use. The Temperature Control Knob should be positioned at or near “COLDEST” setting position depending on the outside temperature, how frequently the cabinet is opened and also the position of the refrigerator in relation to the sun.

6. DEFROSTING

Frost will gradually form on the evaporator.

Since excessive frost accumulation may reduce cooling efficiency, it is recommended to defrost at regular intervals (10 days or so).

How to Defrost:

Turn the Temperature Control Knob (5) or (6) to ‘DEFROST’ position. Make sure that the Defrost (Drip) Tray (3) under the evaporator is located at the correct position before starting the defrosting operation.

Empty ice trays and fill them with hot water if possible to shorten the length of defrosting time.

This practice may cause the frost to melt away sooner and help prevent the food compartment from warming up.

As soon as the frost build-up has completely disappeared, empty the Defrost Tray. (3) under the evaporator, and then clean the interior of the cabinet. Refer to next Para. 7 Cleaning.

IMPORTANT

When adjusting the temperature, be sure to handle the correct Control Knob:

Control Knob (5) when operating on Gas and Control Knob (6) for the operation on Electricity.

7. CLEANING

It may be the best time to make effective cleaning of the cabinet interior and other parts of the refrigerator every time after the defrosting has been exercised. Remove all stored foods. Wash out cabinet with mild soap and water. Rinsing with a solution of baking soda and water is recommended.

IMPORTANT

Don’t use abrasive or caustic cleaning powder, polishes, cleaning paste, gasoline, turpentine or the like. Use a damp cloth for wiping and finish with a soft dry cloth.

8. INTERCHANGING OF DOOR OPENING

The door hinging of this refrigerator has been designed to permit you to arrange either right hand or left hand door opening.

How To Change The Opening:

- 1) Unscrew and remove the top hinge pin
- 2) Remove the door.
- 3) Unscrew and remove the bottom hinge pin and fit it to the opposite side.
- 4) Fit the door to the bottom hinge
- 5) Set the top hinge pin.
- 6) Change the travel latch to the opposite side.

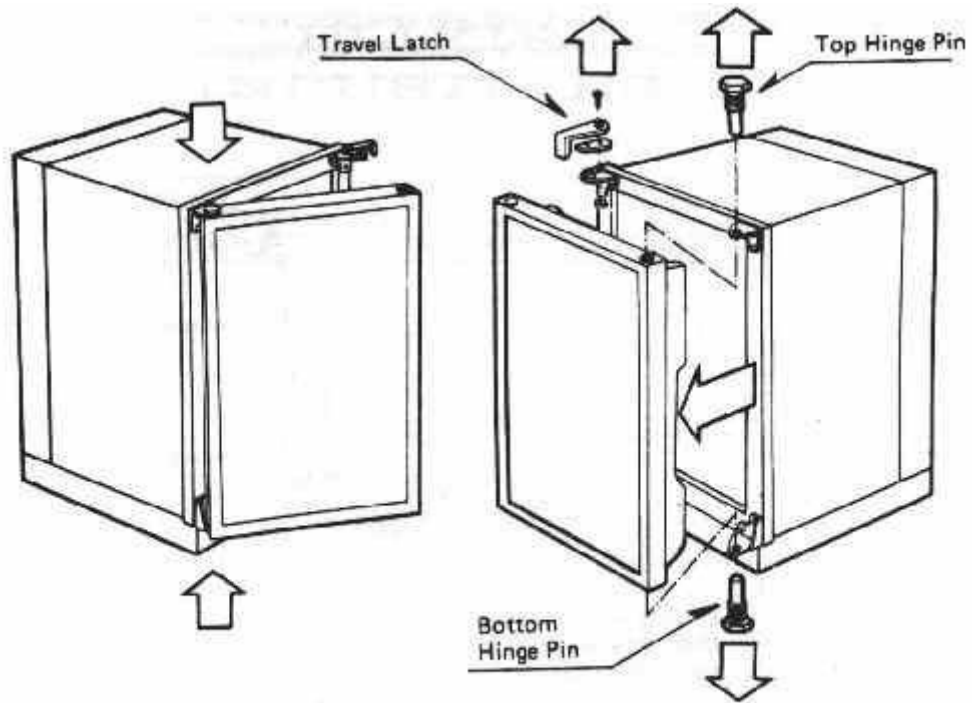

Fig. 3

9. MAINTENANCE INSTRUCTIONS

9-1 Trouble Shooting

If your refrigerator is not working properly, check the following trouble shooting hints. In case your refrigerator still fails to operate, turn the unit off and contact your dealer immediately giving him the model number and the serial number of the refrigerator as given on the data plate and fullest possible details of your problem.

TROUBLE SHOOTING HINTS

Troubles	Probable Causes	Remedies
No burner flame or flame does not stay on.	Thermocouple out of position.	Consult serviceman.
	Dirty or loose lead wire connection of the thermocouple.	Clean and tighten the connection.
	Thermocouple failed.	Replace the thermocouple.
	Safety Device failed.	Replace the safety device.
	Defective Orifice.	Clean or replace the orifice.
Burner remains on low fire, and the cabinet interior can not be cooled sufficiently in spite of the thermostat being set at "COLDEST".	Filter clogged.	Replace the filter.
	Thermostat failed.	Replace thermostat.
	Thermostat out of calibration.	Replace thermostat.
	Supply gas pressure too low.	Check gas supply & adjust to 11" WC
	Filter clogged.	Replace filter.
Burner remains on high flame, and the cabinet interior stays too cold in spite of the thermostat being set at "DEFROST".	Gas supply cock partially closed.	Open the cock all the way.
	Defective orifice.	Clean or replace.
	Valve gas ways clogged.	Consult serviceman.
	Thermostat failed.	Replace the thermostat.
	Thermostat out of calibration.	Replace the thermostat.
Burner flame is soft or yellow.	Burner air passage clogged.	Consult serviceman.
	Flue clogged.	Clean flue.
	Defective or improper orifice function.	Replace the orifice.
	Burner not centered under the flue.	Consult serviceman.
	Burner failed.	Replace burner.
Burner flame is hard.	Defective or improper orifice function.	Replace orifice.
	Baffle missing in the flue.	Replace baffle.
	Improper burner function.	Replace burner.

Note: If this refrigerator is used intermittently, have it checked for proper operation by a qualified serviceman at least once a year.

9-2 Flue Cleaning

It is advisable to clean the flue at reasonable intervals so that it may be maintained free from dust or soot. When cleaning the flue or replacing the flue baffle, be sure to cover the top of the burner with some cloth or the like so that loose scales or other dirt may be prevented from falling into the burner port.

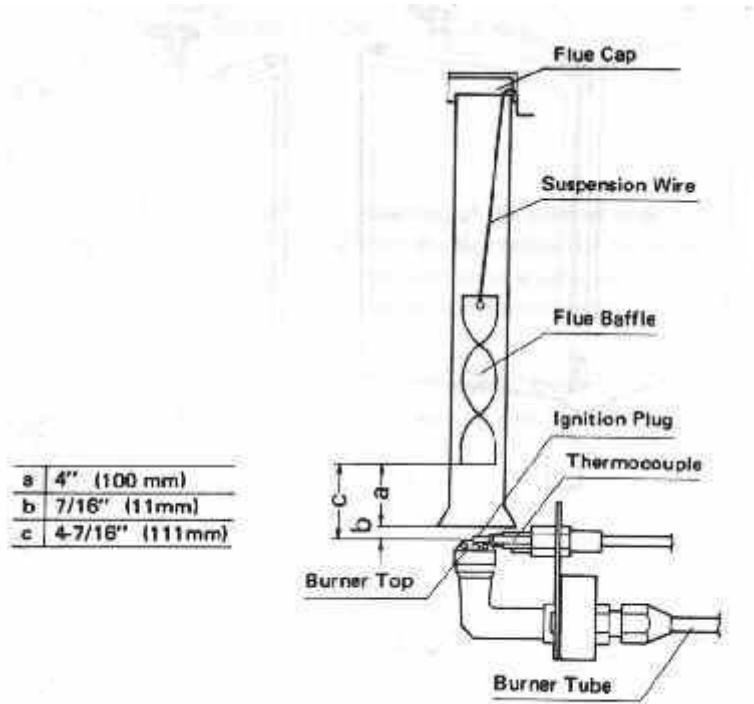

Fig. 4

INSTALLATION INSTRUCTIONS

The refrigerators outlined hereon have been design certified under ANSI Z 21. 19-1975 Refrigerators by the American Gas Association for installation in a recreational vehicle and are approved by the Canadian Gas Association,

The certifications are, however, contingent on the installation being made in accordance with the following instructions.

The installation must conform with the following American National Standards as applicable.

1. National Fuel Gas Code 2223. 1-1974
2. Mobile Homes, A119. 1•1975
3. Recreational Vehicles A1 19. 2-1975
4. The unit must be electrically grounded in accordance with the National Electrical Code ANSI, C1-1975 when installed if an external alternating current electrical source is utilized.
5. Any applicable local code In Canada:
 1. Standard CSA Z240.4 “Gas Equipped Recreational Vehicles and Mobile Housing.
 2. Standard GSA 2240.6.1 “Electrical Requirements for Mobile Homes”.
 3. Standard GSA 2240.6.2/C22.2 No. 148 “Electrical Requirement for Recreational Vehicles”.

VENTILATION

The installation shall be made in such a manner as to separate the combustion system from the living space of the mobile home or recreational vehicle. Louvered openings for air supply or for venting of combustion products shall have a minimum dimension of not less than 1/4 inch,

The installation requires one lower fresh air intake and one upper exhaust vent, The ventilation kits shown in this instruction booklet are for use with the refrigerator models identified.

The refrigerator must be installed using the vent kit supplied with the refrigerator. The proper manner of installing the vent kit is illustrated in figures 7 through 9. Use the figure applicable to the vent kit number supplied with the refrigerator.

The vent kit supplied with the refrigerator must not be modified in any way. An opening at floor level of the refrigerator, communicating with the outside atmosphere must be provided for ventilation of heavier-than-air gases. The bottom louvers of the lower louver panels serve this purpose. The opening area of the bottom louvers of each lower louver panel must be more than 1.2 in² (8cm²). The bottom louvers must be installed at floor level and be completely unobstructed.

GAS CONNECTION

Hook-up to the gas supply line is accomplished at the 3/8” SAE male flare connector. All completed connections should be checked for leaks with soapy water. The gas supply system must incorporate a pressure regulator to maintain a supply pressure of 11 inches water column.

ELECTRICAL CONNECTION

117 VOLTS AC.

The refrigerator is equipped with a three prong (grounded) plug for protection against shock hazards and should be plugged directly into a properly grounded three prong receptacle. Do not cut or remove the grounding prong from this plug. The cord should be routed to avoid coming in contact with the burner cover, flue cover or other hot components.

12 VOLTS D.C.

On “3-Way” units there is an additional connection for “12V”. The refrigerator must be connected to the battery circuit with two wires of adequate capacity to avoid voltage drop. The wire gage should be chosen with consideration to the wire length in accordance with the following table.

TABLE

Maximum two conductor wire length for different AWG numbers.

AWG	MAXIMUM TWO CONDUCTOR WIRE LENGTH IN FEET			
	MODEL <u>202-90</u>	MODEL <u>302-90</u>	MODEL <u>402-90</u>	MODEL <u>602-90</u>
14	10	9	7	6
12	17	15	12	9
10	27	25	19	15
8	43	40	31	24
6	69	64	49	38
4	110	102	79	61

The wire length includes distance from positive battery to the refrigerator and return to negative battery.

Example: (Model 202-90. 14 AWG, 10 feet) The refrigerator can only be a distance of 5 feet of wire length from the battery.

Do not use the body or chassis of the vehicle as a substitute for either of the two conductors. No other electrical equipment or lighting should be connected to the refrigerator circuit. The refrigerator will draw from 8 to 17 Amps at 12 Volts depending on model.

CAUTION

Do not operate the refrigerator on 12 Volts when the vehicle is parked. You will run out of battery in a rather short time.

If possible the installation of a 12 Volts operated refrigerator should be completed with a relay mounted either in the car or in the recreational vehicle. This relay will automatically cut out the refrigerator when the car motor is stopped.

SPECIAL HINTS

The refrigerator must be installed in a substantial enclosure and must be level. A spirit level is supplied with each refrigerator and by placing it in the freezer compartment, one can level the refrigerator both ways front to back and side to side. When installing the refrigerator in the enclosure, care should be taken to ensure a complete sealing between the front frame of the refrigerator and the top sides and bottom of the enclosure. For this purpose a length of sealing strip is shipped with each refrigerator.

The strips should be applied to the rear surfaces of the front frame of the refrigerator and to the foremost bottom surface of the enclosure as shown in Fig. 5.

Be careful not to damage the sealing strip applied to the bottom of the enclosure when the refrigerator is put in place.

Any space between counter or storage area and the top of the refrigerator must be blocked. The heat produced at the rear of the refrigerator will otherwise become trapped in this space making the top of the refrigerator hot and reducing the efficiency of the refrigerator.

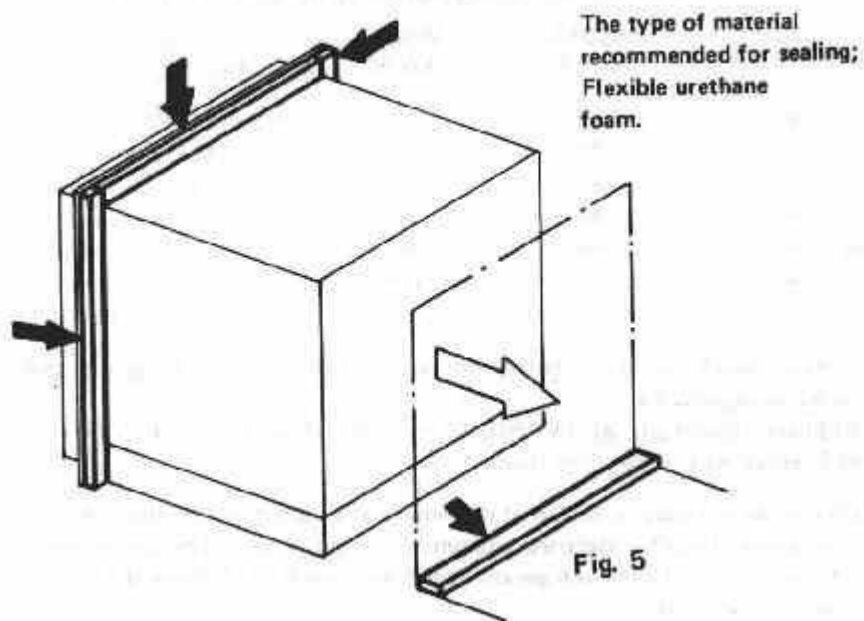

APPROVED VENTING COMPONENTS



No. 430H ROOF VENT
Cutout Requirements
4-1/2 x 20-1/2
Unit has sheet metal
base and ABS plastic top.

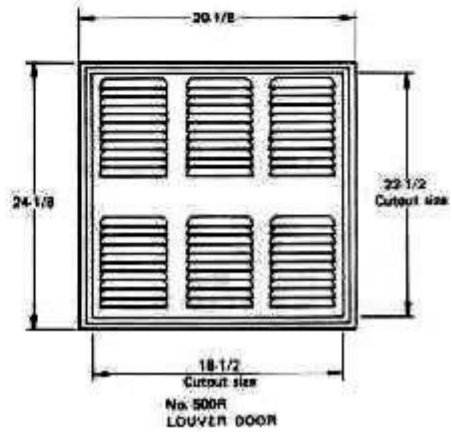
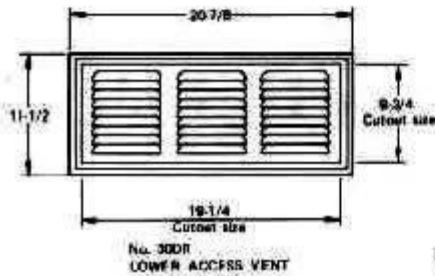
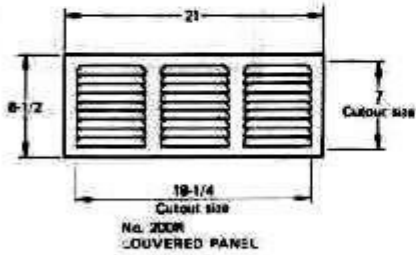
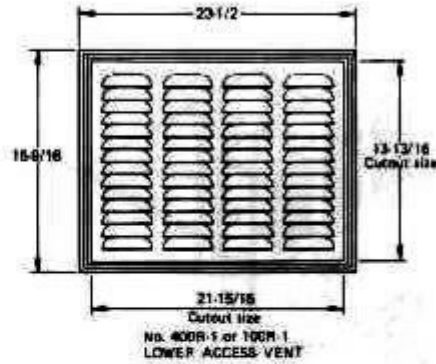
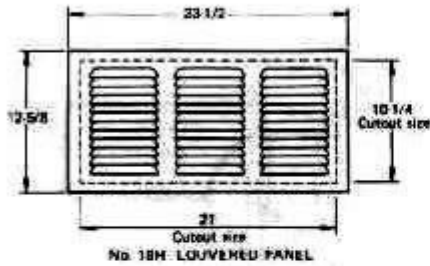

Fig. 6

**MODEL 202-90
INSTALLATION
VENT KIT No. 746H-8 or No. 200H**

VENT KIT No.	LOUVERED PANEL	LOWER ACCESS VENT
No. 746H-8	No. 18H	No. 400R-1 or No. 100R-1
No. 200H	No. 200R	No. 300R

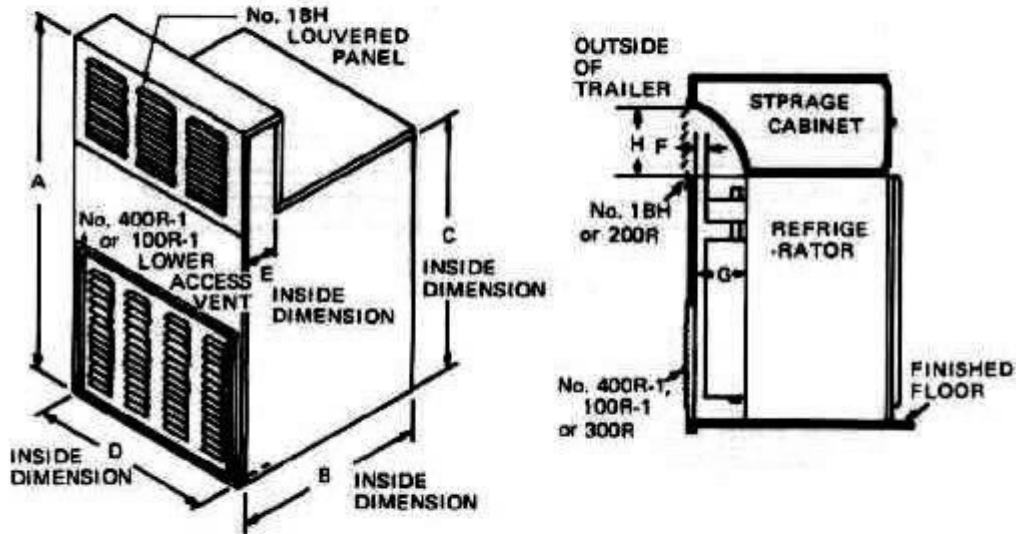

Fig 7

Model No.	A		C	D	H	Recommended				Minimum			
	Min.	Max.				B	E	F	G	B	E	F	G
202-90	33-1/2	71-13/16	21-1/2	19-5/8	11-1/2	19-1/8	5	1	5	18-1/8	4	0	4

**MODEL 202-90
INSTALLATION
VENT KIT No. 746H-9**

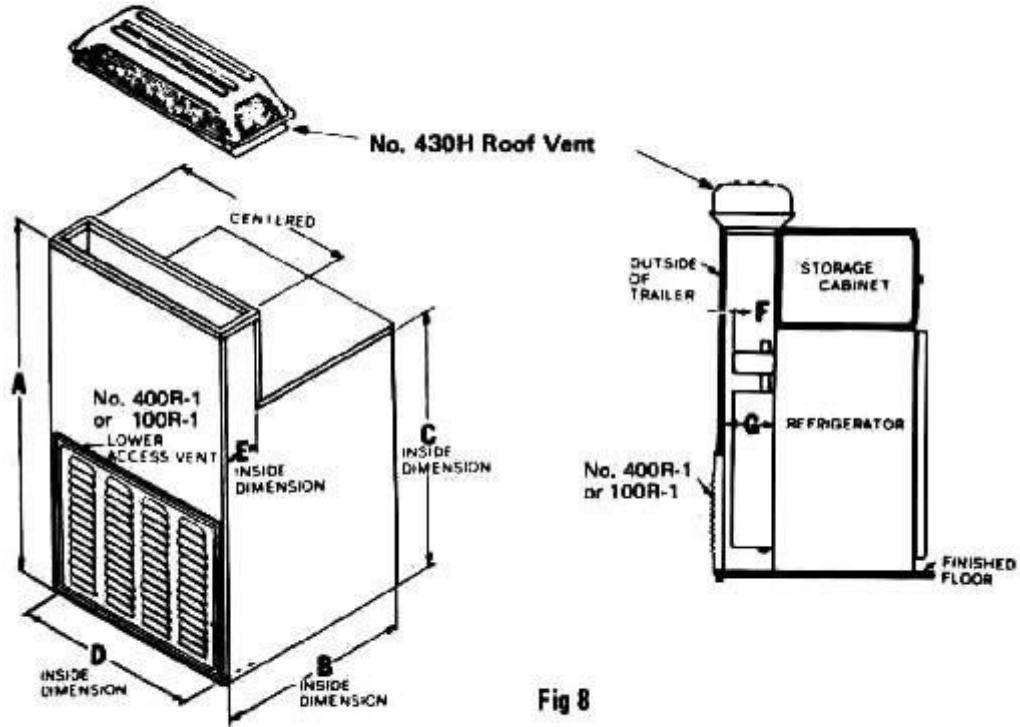

Fig 8

Model No.	A		C	D	Recommended			Minimum				
	Min.	Max.			B	E	F	G	E	F	G	
202-90	33- ³ / ₄	71-13/ ₁₆	21-1/ ₂	19-5/ ₈	19-1/ ₈	5	1	5	18-1/ ₈	4	0	4

**MODEL 202-90
INSTALLATION
VENT KIT No. 250H**

VENT KIT No.	UPPER AND LOWER LOUVER DOOR
No. 250H	No. 500R

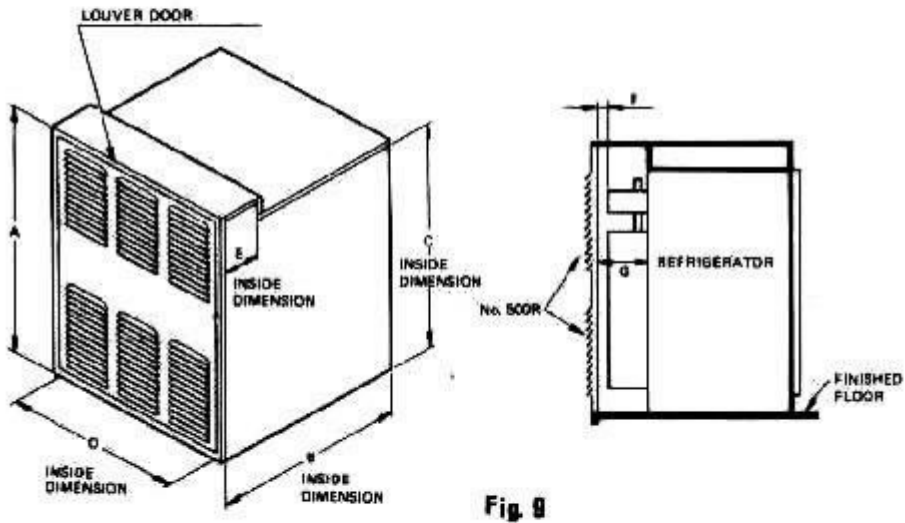

Fig. 9

Model No.	A	C	D	Recommended				Minimum			
				B	E	F	G	B	E	F	G
202-90	24-1/8	21-1/2	19-5/8	19-1/8	5	1	5	18-1/8	4	0	4